

**SUMMERSET CITY COMMISSION
REGULAR MEETING
SUMMERSET MUNICIPAL BUILDING
7055 LEISURE LANE
THURSDAY JUNE 4, 2020 6:00 P.M.**

AGENDA

1) ROLL CALL

Kitzmilller, McCoy, Butler, Lutz, Hirsch

2) PLEDGE OF ALLEGIANCE

3) CALL FOR CHANGES

Approval of the Agenda of the Regular Meeting of the Summerset City Commission for June 4, 2020 as presented or amended.

4) CONSENT CALENDAR

APPROVAL OF THE MINUTES

- 4A)** Approval of the minutes of the Regular Meeting May 21, 2020 as presented or amended.

APPROVAL OF THE CLAIMS

- 4B)** Approval of claims, hand checks and payroll checks in the amount of \$154,699.23 from May 22, 2020 to June 4, 2020 as presented or amended.

5) APPOINT COMMISSIONER

5A) Administer Oath of Office to Bryce Lutz appointed Mayor for a term of one year.

5B) Administer Oath of Office to Stephanie McCoy elected Commissioner for a term of three year.

5C) Administer Oath of Office to Michael Kitzmilller elected Commissioner for a term of three year.

6) ELECTION OF THE PRESIDENT OF THE SUMMERSET CITY COMMISSION

- 7) **APPOINTMENT OF COMMISSIONERS**
To be done by majority vote for the following:
 - Public Safety
 - Public Works
 - Utilities, and
 - Finance and Revenue
- 8) **APPOINTMENT OF CITY OFFICIALS:**
 - City Attorney
 - City Engineering Firm
 - City Finance Officer
- 9) **DISCUSSION OF NOISE REGULATIONS AND LIMITATION ORDINANCE**
- 10) **FIRST READING OF NOISE REGULATIONS AND LIMITATION ORDINANCE**
- 11) **APPROVAL OF RESOLUTION 2020-06**
Approval of Resolution 2020-06. Resolution authorizing execution of purchase order and contract, and expenditure of fund for Wastewater Treatment Plant improvement.
- 12) **UTILITY BILLING ADJUSTMENTS**
Approval of utility billing adjustments of \$495.70 for the period May 1, 2020-May 31, 2020.
- 13) **PAYROLL CHANGE**
Part time Code Enforcement Officer, Dan Anderson, within budget, at \$14.50/hour.
- 14) **CITIZENS INPUT**
- 15) **ITEMS FROM CITY ATTORNEY**
Executive Session per SDCL 1-25-2 for discussing legal, economic development, and personnel issues.
- 16) **ADJOURNMENT**

Information regarding accessibility for the disabled may be obtained by calling the Summerset City Finance Officer at 605-718-9858. Individuals needing special accommodations are asked to call at least 48 hours prior to the meeting.

ALL MEETINGS OF THE SUMMERSET CITY COMMISSION ARE OPEN TO THE PUBLIC

In relation to the COVID-19 virus, and in following guidelines from the CDC in relation to minimizing exposure, the City will have a call-in number available (instructions below) for Thursday's City Commission meeting. For those that wish to participate in the meeting remotely, we encourage you to follow the instructions below.

Call-in instructions:

Topic: Commission Meeting

Time: Jun 4, 2020 06:00 PM Mountain Time (US and Canada)

Join Zoom Meeting

<https://us02web.zoom.us/j/84717409266?pwd=S3JTMnBtZExPZnlobWV6OTVocHpzQT09>

Meeting ID: 847 1740 9266

Password: 838513

One tap mobile

+12532158782,,84717409266#,,1#,838513# US (Tacoma)

+13462487799,,84717409266#,,1#,838513# US (Houston)

Dial by your location

+1 253 215 8782 US (Tacoma)

+1 346 248 7799 US (Houston)

+1 669 900 9128 US (San Jose)

+1 301 715 8592 US (Germantown)

+1 312 626 6799 US (Chicago)

+1 646 558 8656 US (New York)

Meeting ID: 847 1740 9266

Password: 838513

**SUMMERSET CITY COMMISSION
PUBLIC HEARING
SUMMERSET MUNICIPAL BUILDING
7055 LEISURE LANE
THURSDAY MAY 21, 2020 6:00 P.M.**

Mayor Lutz called the Public Hearing to order at 6:00 p.m. Commissioners Kitzmiller, Hirsch, Butler and McCoy were present. Also present was the, City Attorney, City Finance Officer and City Administrator.

Mayor Lutz led the Pledge of Allegiance.

Motion by Hirsch, second by McCoy to approve the agenda for May 21, 2020. Motion carried

Motion by Kitzmiller, second by Hirsch to approve the May 7, 2020 Minutes as presented. Motion carried.

APPROVAL OF CLAIMS

Motion by Hirsch, second by McCoy to approve the claims and hand checks in the amount of \$34,595.43, from May 8, 2020 through May 21, 2020 as amended. Motion carried.

A&B BUSINESS SOLUTIONS	Professional Services	187.09
AFLAC REMITTANCE	Accidental Insurance	217.36
BLACK HAWK WATER	Govt Utilities	30.00
BLACK HILLS ENERGY	Govt Utilities	5,280.93
CINDY HERDING	WWTP Deposit Refund	100.00
DANIEL ALLARD	WWTP Deposit Refund	50.00
DEMERSSEMAN JENSEN	Legal Services	1,050.00
GOLDENWEST TECHNOLOGIES	Professional Services	125.00
HDR ENGINEERING, INC	Professional Services	5,537.50
HERMANSON EGGE	Professional Services	885.00
KIEFFER SANITATION	Sanitation Expense	14,338.42
MDU	Govt Utilities	289.41
MEADE COUNTY AUDITOR	Dispatch Expense	2,202.41
MEADE COUNTY REG OF DEED	Plat Expense	90.00
MID-AMERICAN RESEARCH	WWTP Supplies	641.95
MIDCONTINENT COMMUNICATIONS	WWTP Utilities	191.95
RAPID CITY JOURNAL	Publishing Expense	79.96
SD DEPT OF REVENUE	Malt Beverage Renewal	900.00
SD DEPT OF REVENUE	Liquor License Transfer	75.00
SD ONE CALL	Locating Expense	44.10
TNT CONSTRUCTION	Erosion Control Deposit Refund	1,000.00
VERIZON WIRELESS	LE Utilities	200.05
WELLS FARGO FINANCIAL	Street Auto Expense	1,079.30

PUBLIC HEARING

Motion by Kitzmiller, second by Hirsch to enter into public hearing. Motion carried.

Public input was heard regarding an application for new Retail (on-sale) Liquor- from Angel's Catering, 12340 Jenter Rd., Summerset, SD 57718, at Lot B of LW-124 3-6 Stagesop Subdivision, City of Summerset, Meade County, South Dakota.

Motion by Kitzmiller, second by McCoy to close the public hearing. Motion carried.

Motion by Kitzmiller, second by Butler to approve the application for new Retail (on-sale) Liquor- from Angel's Catering, 12340 Jenter Rd., Summerset, SD 57718, at Lot B of LW-124 3-6 Stagesop Subdivision, City of Summerset, Meade County, South Dakota. Roll call vote. All ayes.

RESOLUTION 2020-05

**CITY OF SUMMERSET
RESOLUTION 2020-05**

WHEREAS, there has been presented to the Board of Commissioners, of the City of Summerset, South Dakota a plat of the following described real property:

Final Plat of Lot14R and Lot 15R of High Meadows Subdivision, Formerly Lots 14 and 15 of High Meadows Subdivision, Located in the W 1/2 of the NE 1/4 of the SE 1/4 of Section 36, Township 3 North, Range 6 East, Black Hills Meridian, Meade County, South Dakota

and it appearing to the Board of Commissioners that said plat conforms to the existing plats of said City of Summerset, that the streets set forth therein conform to the system of streets of the municipality, that all provisions of the subdivision regulations have been complied with, that all taxes and special assessments upon the land have been fully paid, and that said plat and survey thereof have been executed according to law.

NOW THEREFORE BE IT RESOLVED that said plat is hereby approved in all respects.

Dated this 21st Day of May 2020.

ATTEST:
(SEAL)

Debbie Muzio
Finance Officer

Bryce Lutz
Mayor

Motion by Butler, second by Hirsch to approve Resolution 2020-05. Resolution approving preliminary and final plat application from Paul Wilson: Preliminary and final plat application of Lot 14R and Lot 15R of High Meadows Subdivision, Formerly Lots 14 and 15 of High Meadows Subdivision, Located in the W 1/2 of the NE 1/4 of the SE 1/4 of Section 36, Township 3 North, Range 6 East, Black Hills Meridian, Meade County, South Dakota. Roll call vote. All ayes.

MALT BEVERAGE LICENSE RENEWALS 2020-2021

Motion by Kitzmiller, second by McCoy to approve the application for Retail On-Off Sales Malt Beverage & SD Farm Wine License #RB-25545 with Sunday Service and eight video lottery machines, The Pit Stop LLC, 8034 Stagestop Road, OC.60.02R, Lot 2R. 23-3-6

Motion by Butler, second by McCoy to approve the application for Retail On-Off Sale Malt Beverage and SD Farm Wine License #RB-25543 with Sunday Service, JR's Rhodehouse BBQ Pit, 7201 Infinity Drive, Summerset, SD 57718, OC.68.04, Infinity Business Park, Sub Lot 4

Motion by Kitzmiller, second by Hirsch to approve the application for Retail On-Off Sale Malt Beverage and SD Farm Wine License #R25544 with Sunday Service, Dolgen Midwest LLC 100 Mission Ridge, Goodlettsville TN 37072. DBA Dollar General-12000 Sturgis Road, Summerset, SD 57718, OC.55.1R.0C, Sioux Land Estates Sub Lot C of Tract 1R.

RESOLUTION 2019-04-MALT BEVERAGE LICENSE RESOLUTION

**CITY OF SUMMERSET
RESOLUTION 2020-04**

MALT BEVERAGE LICENSE RENEWAL RESOLUTION

WHEREAS, the City of Summerset, Meade County, a South Dakota municipal corporation having the authority to enforce all statutes and ordinances within its corporate boundaries, and to pass resolutions regarding legal issues concerning the municipality;

AND WHEREAS, The City of Summerset Council of Commissioners has duly reviewed and examined renewal applications in a Regular Meeting held on May 7, 2020 and May 21, 2020;

NOW THEREFORE, BE IT RESOLVED by the City of Summerset Council of Commissioners that the following licenses be approved and renewed for the 2020-2021 license year:

Retail On-Off Sale Malt Beverage and SD Farm Wine License # RB-25546 with Sunday Service, TFH Inc., dba Haggar's Grocery, 8031 Stagestop Road, Lot 2R of Tract 1R of Siouxland Estates, NW ½ of Sec 25, T3N, R6E, BHM, Summerset, Meade County, South Dakota.

Retail On-Off Sale Malt Beverage and SD Farm Wine License #RB-2318 with Sunday Service and eight video lottery machines, MG Oil Company, dba Happy Jacks - Summerset, 8076 Stagestop Road, Lot SC4 and SC5 Siouxland Estates, Sec 23, T3N, R6E, BHM, Summerset, Meade County, South Dakota.

Retail On-Off Sale Malt Beverage and SD Farm Wine License #RB-18919 with Sunday Service and ten video lottery machines, MG Oil Company, dba Happy Jacks – Summerset 2, 8074 Stagestop Road, Lot SC4 and SC5, Siouxland Estates, Sec 23, T3N, R6E, BHM, Summerset, Meade County, South Dakota.

Retail On-Off Sale Malt Beverage and SD Farm Wine License #RB-25545 with Sunday Service and eight video lottery machines, The Pit Stop LLC, 8034 Stagestop Road, OC.60.02R, Lot 2R. 23-3-6.

Retail On-Off Sale Malt Beverage and SD Farm Wine License #RB-25543 with Sunday Service, JR's Rhodehouse BBQ Pit, 7201 Infinity Drive, Summerset, SD 57718, OC.68.04, Infinity Business Park, Sub Lot 4.

Retail On-Off Sale Malt Beverage and SD Farm Wine License #R25544 with Sunday Service, Dolgen Midwest LLC 100 Mission Ridge, Goodlettsville TN 37072. DBA Dollar General-12000 Sturgis Road, Summerset, SD 57718, OC.55.1R.0C, Sioux Land Estates Sub Lot C of Tract 1R.

BE IT FURTHER RESOLVED that a copy of this Resolution be forwarded to the Department of Revenue and Regulation, Special Tax Division along with the applications and fees for the 2020-2021 license term.

Dated this 21st day of May 2020.

(SEAL)
ATTEST:

Debbie Muzio
Finance Officer

Bryce Lutz
Mayor

Motion by McCoy, second by Butler to approve Resolution 2020-04. A resolution approving Malt Beverage Licenses for the City of Summerset. Roll call vote. All ayes.

APPROVAL OF PURSUING LOAN OPTIONS FOR WATER WARRIORS PROJECT

Discussion was done on loan options for the Water Warriors Project. No action was taken.

UPCOMING EVENTS

Election-June 2, 2020

City wide clean up-June 12&13

CITIZENS INPUT

None

ADJOURNMENT

Motion for adjournment at 6:37 pm by Hirsch, second McCoy. Motion carried.

(SEAL)

ATTEST:

Debbie Muzio
Finance Officer

Bryce Lutz
Mayor

Check Register Report

Date: 06/02/2020

Time: 10:48 pm

Page: 1

City of Summerset

BANK: FIRST INTERSTATE BANK

Check Number	Check Date	Status	Void/Stop Date	Reconcile Date	Vendor Number	Vendor Name	Check Description	Amount
FIRST INTERSTATE BANK Checks								
22895	06/04/2020	Printed			0962	ALLEN, DON	Cell Phone Allowance	50.00
22896	06/04/2020	Printed			0962	ALLEN, DON	Uniform Allowance	400.00
22897	06/04/2020	Printed			1111	AMBROSE, JONATHAN	Cell Phone Allowance	50.00
22898	06/04/2020	Printed			1572	ANDERSON, DAN	Cell Phone Allowance	50.00
22899	06/04/2020	Printed			0095	Butler, Dave	Cell Phone Allowance	50.00
22900	06/04/2020	Printed			0468	DELTA DENTAL		498.60
22901	06/04/2020	Printed			1251	FIRST INTERSTATE BANK		855.74
22902	06/04/2020	Printed			1251	FIRST INTERSTATE BANK		4,911.76
22903	06/04/2020	Printed			1120	FORD MOTOR CREDIT COMPANY, LLC		1,479.21
22904	06/04/2020	Printed			0246	GOLDEN WEST TECHNOLOGIES		1,862.50
22905	06/04/2020	Printed			0246	GOLDEN WEST TECHNOLOGIES		62.50
22906	06/04/2020	Printed			1369	GREENAPSIS		280.00
22907	06/04/2020	Printed			0274	HARMON, LONNIE	Cell Phone Allowance	50.00
22908	06/04/2020	Printed			0041	HEALTH POOL OF SD		8,531.74
22909	06/04/2020	Printed			1513	HIRSCH, CLYDE	Cell Phone Allowance	50.00
22910	06/04/2020	Printed			1082	JIM'S PRIVATE UTILITY LOCATING		112.50
22911	06/04/2020	Printed			1566	JUSO, COLTON	Cell Phone Allowance	50.00
22912	06/04/2020	Printed			1566	JUSO, COLTON	Uniform Allowance	400.00
22913	06/04/2020	Printed			1103	KITZMILLER, MICHAEL	Cell Phone Allowance	50.00
22914	06/04/2020	Printed			0052	LUTZ, BRYCE	Cell Phone Allowance	50.00
22916	06/04/2020	Printed			1172	MASTERCARD		4,515.68
22917	06/04/2020	Printed			1411	MBFS USA LLC		3,068.32
22918	06/04/2020	Printed			1408	PALMER, BRANDY	Uniform Allowance	400.00
22919	06/04/2020	Printed			1408	PALMER, BRANDY	Cell Phone Allowance	50.00
22920	06/04/2020	Printed			0008	RAPID CITY JOURNAL		153.65
22921	06/04/2020	Printed			1022	SDRS-SUPPLEMENTAL		420.00
22922	06/04/2020	Printed			1346	STEPHANIE MCCOY	Cell Phone Allowance	50.00
22923	06/04/2020	Printed			0983	TANNER FENENGA	Cell Phone Allowance	50.00
22924	06/04/2020	Printed			1235	TAYLOR, JUSTIN	Cell Phone Allowance	50.00
22925	06/04/2020	Printed			1235	TAYLOR, JUSTIN	Uniform Allowance	400.00
22926	06/04/2020	Printed			1347	TELEDYNE INSTRUMENTS, INC		390.86
22927	06/04/2020	Printed			1432	TNT CONSTRUCTION		1,000.00
22928	06/04/2020	Printed			1432	TNT CONSTRUCTION	Erosion Control Deposit	1,000.00
22929	06/04/2020	Printed			0056	UNITED STATES POSTAL SERVICE		1,000.00
22930	06/04/2020	Printed			0056	UNITED STATES POSTAL SERVICE		240.00
22931	06/04/2020	Printed			1024	USA BLUEBOOK		641.78
22932	06/04/2020	Printed			1189	VAST		751.97
22933	06/04/2020	Printed			1607	WATER WARRIORS, INC	40% of Project	88,606.00

Total Checks: 38

Checks Total (excluding void checks):

122,632.81

Total Payments: 38

Bank Total (excluding void checks):

122,632.81

Total Payments: 38

Grand Total (excluding void checks):

122,632.81

Direct Deposit - ACHA Preview

City of Summerset
Emp.Code Desc.:SDSUM

Date: 5/26/2020
Time: 13:34:12

Employee ID	Employee Name	Bank Routing Number	Account Number	Acct.Type	Amount
ALLEND	ALLEN, DONALD D	291479592	146868002	C	\$3,349.40
AMBROSEJ	AMBROSE, JONATHAN D	091400486	500014070	C	\$3,175.90
ANDERSONE	ANDERSON, DANIEL	091400046	1057990267	C	\$1,141.57
BEWLEYD	BEWLEY, ORVILLE D	291479592	141529002	C	\$69.26
BRAKKES	Brakke, Sheldon	091400538	1000064475	C	\$152.38
BUTLERD	DAVID, BUTLER	291479291	52249	S	\$511.20
CHRISTM	Christensen, Marcus R	291479356	81362098	C	\$69.26
FENENGAT	FENENGA, TANNER	091409733	706754	C	\$3,164.19
FORBESN	FORBES, NICOLIS J	091400046	1055332553	C	\$236.18
HARMONL	HARMON, LONNIE J	092901683	3301634	C	\$3,267.71
HIRSCHC	HIRSCH, CLYDE A	291479592	030391084	C	\$486.20
JOHNSONS	JOHNSON, SCOTT	091400525	900038450	C	\$552.98
JUSOC	JUSO, COLTON	091400538	1000048135	C	\$2,488.50
KITZMILLER	KITZMILLER, MICHAEL J	291479592	22139001	S	\$538.70
LUTZB	LUTZ, BRYCE J	291479592	52132002	C	\$722.95
MCCOYS	MCCOY, STEPHANIE	091408501	175091113530	C	\$538.70
MUZIOD	MUZIO, DEBRA L	291479592	160396002	C	\$3,323.16
OLDFIELDB	Oldfield, Brody R	314074269	236313746	C	\$69.26
OSTENM	OSTEN, MICHAEL	091310521	650124712	C	\$69.26
RYANB	PALMER, BRANDY N	291479592	150658002	C	\$2,607.03
SEALEYC	SEALEY, CANDACE L	091408734	13530074	C	\$2,272.31
TAYLOR	TAYLOR, JUSTIN P	091408763	31802814	C	\$3,191.06
WILSONG	WILSON, GREGORY L	091400046	2755231814	C	\$69.26
				Total Amount:	\$32,066.42

NOISE REGULATION AND LIMITATION

- A. The purpose and intent of this section is to protect, preserve and promote the health, safety, welfare, peace, quiet and tranquility for the citizens and persons or visitors frequenting the city through the reduction, control and prevention of noise which is disruptive and constitutes an annoyance to such citizens and persons.
- B. General Restrictions
1. A person or property owner may not:
 - a. Make or permit any disruptive noise or use sound equipment in public or outside between 10pm and 8am;
 - b. Operate construction equipment, tools or conduct construction activities between 7pm and 7am;
 - c. Operate sound equipment in a vehicle causing any disruptive noise or a discernible vibration twenty (20) feet from the vehicle.
 2. In addition to the specific prohibitions outlined in subsection A, it is unlawful for any person to make, continue, or cause to be made or continued any loud or unusual noise so as to disturb the peace of the public, any neighborhood, any business operation, family, lawful assembly of persons or a person by committing any act or acts of disturbance within the City limits.
 3. Excessive Vehicle Noise and Dynamic Engine Braking:
It is unlawful for any person within the city limits of the City to make, or cause to be made, loud or disturbing or offensive noise with any mechanical devices operated by compressed air and used for purposes of assisting braking such as Dynamic Engine Braking Devices. (Commonly referred to as “Jake” brake).
 4. Penalty:
Any violation of this ordinance will be punishable by a fine of \$100 for each offense, in addition to the payment of any costs and/or restitution authorized by Summerset Ordinances and/or state law.

CITY OF SUMMERSET

RESOLUTION AUTHORIZING EXECUTION OF PURCHASE ORDER AND CONTRACT,
AND EXPENDATURE OF FUNDS FOR WASTEWATER TREATMENT PLANT
IMPROVEMENT

2020-06

WHEREAS, the City of Summerset Board of Commissioners is charged with the duty and responsibility of operating, maintaining, and improving the City's Wastewater Treatment Plant; and

WHEREAS, the City has received a proposal from Water Warriors, Inc, dated June 2, 2020, detailing a scope of work intended to expand the Sequential Batch Reactor ("SBR") process currently utilized at the Wastewater Treatment Plant for the purpose of increasing the facility's overall treatment capacity; and

WHEREAS, the proposal and plan has been reviewed by the City Engineer, HDR Engineering, as reflected in a draft memo dated May 7, 2020; and

WHEREAS, the anticipated cost for the treatment plant improvement to the SBR as set forth in the proposal dated June 2, 2020, and the purchase order dated June 3, 2020, is \$221,515.00; and

WHEREAS, the City Board of Commissioners has previously found and determined that this proposal comes from Water Warriors, Inc, as a sole source of procurement as the services and improvements are of such a unique nature that the contractor selected, Water Warriors, Inc, is clearly and justifiably the only practicable source to provide the supplies, services, and improvements in accordance with SDCL 5-18A-8 and SDCL 5-18A-10, and that the City will maintain the records of the sole source procurement for a minimum of five (5) years, which shall include the contractors name, the amount and type of the contract, and the listing of the supplies, services, and public improvements procured under the contract all in an accordance with SDCL 5-18A-10; and

WHEREAS, there are sufficient funds in the Wastewater Treatment Plant reserve account to pay for the costs of this public improvement, and that the City is authorized to use said funds for this purpose.

NOW THEREFORE BE IT RESOLVED:

1. That the Mayor of the City of Summerset be and hereby is authorized to execute the purchase order referenced above, dated June 3, 2020, pertaining to and encompassing the

scope of work included in the Water Warriors, Inc proposal and further is authorized to execute a contract for this improvement to the Wastewater Treatment Plant.

2. That the City is authorized to expend funds from the Wastewater Treatment Plant reserve account for this project provided it maintains sufficient amounts in that account in accordance with South Dakota Law and the applicable provisions set forth in any bond documents and resolutions.

3. That the Mayor on behalf of the City is authorized to execute change orders pertaining to this project, if any, as it progresses, provided the same are reviewed by and approved by the City Engineer, HDR Engineering, and legal counsel.

ATTEST:

Debbie Muzio
Finance Officer

Bryce Lutz
Mayor

UPGRADING SEQUENTIAL BATCH REACTOR TREATMENT PROCESS

Proposal Submitted to:

Mr. Jon Ambrose
City of Summerset
Wastewater Superintendent
7055 Leisure Lane
Summerset, SD 57718

Proposal Submitted by:

Water Warriors, Inc.
1776 Mentor Avenue; STE 400F
Cincinnati, OH 45212, USA
Attn: Steve Chamberland
Mobile: +1(859) 629-2236

May 2020v4

**Proposal for
Retrofitting and Upgrading the City of Summerset, South Dakota**

**Treatment Plant, located at
7055 Leisure Lane
Summerset, South Dakota 57718
(refer to attached document)**

**Submitted by:
Water Warriors, Inc.
1776 Mentor Avenue; STE 400F
Cincinnati, OH 45212**

Approval Signatures

_____	_____
Name and Position	Date
_____	_____
Name and Position	Date
_____	_____
Name and Position	Date
_____	_____
Name and Position	Date

Water Warriors, Inc.

_____	_____
John Gradek, CEO	Date

INTRODUCTION

The city of Summerset operates a Sequential Batch Reactor (SBR) wastewater treatment plant, which has the following characteristics:

WATER WARRIORS, INC.		
SEQUENTIAL BATCH REACTOR PARAMETERS		
Enter values in the green colored cells only		
Influent Flow Parameters		
Flowrate (MGD)	0.18	MGD
Suspended Solids (mg/L)	200	mg/L
Volatile Suspended Solids (VSS)		mg/L
Temperature (deg F)	65	deg F
Biological Oxygen Demand (BOD) (mg/L)	250	mg/L
Hydraulic Retention Time (hrs)	5.2	hrs
Ammonia concentration (mg/L)		mg/L
Total Nitrogen (mg/L)		mg/L
Total Phosphorus (mg/L)		mg/L
pH	7	
Reactor		
Number of Reactors	2	
Total volume of each reactor (Gallons)	170,000	gallons
% of Total volume filled with wastewater	11	%
Fill time of Reactor (hr)	2.67	hrs
Treatment Time (hr)	5.2	hrs
Decant Time (hr)	0.8	hrs
Aeration Rate (acfm)		acfm
Power consumption by Blowers (HP)	25	HP
Effluent		
Suspended Solids (mg/L)	5	mg/L
Volatile Suspended Solids (VSS)		mg/L
Biological Oxygen Demand (BOD) (mg/L)	5	mg/L
Ammonia concentration (mg/L)	0.05	mg/L
Total Nitrogen (mg/L)	1	mg/L
Total Phosphorus (mg/L)	1	mg/L
pH	7.3	

The objective of this proposal is to provide a retrofittable, cost-effective solution for increasing plant capacity, improve effluent water quality, reduce energy consumption and decrease sludge production.

PROPOSED TECHNOLOGIES

There are two technologies which are proposed to achieve the objectives of this document. These two technologies are:

1. Waving Biomedia;
2. Microbubble Aeration

Validation case studies for these two proposed technologies are attached in Appendix 1.

Waving Biomedia: Waving Biomedia was developed as a hybrid between fixed and moving biomedias. Fixed biomedia is typically placed inside the lagoon or treatment system, and consists of plastic plates, bonded together to form a high surface area structure. The main issue with fixed biomedia is with respect to growth of biomass and deposition of suspended solids that eventually results in clogging of the biomedia, and the liquid flow begins to by-pass the fixed media, which decreases treatment efficiency. Moving biomedia, consists of small 1in. diameter plastic pieces, which are neutrally buoyant, and grow biofilms on their surface. Typically 50-60% of treatment volume is occupied by the moving media, which reduces treatment capacity substantially and these plastic pieces have to be retained using a screen at the exit of the treatment zone. In addition, due to the large number of plastic pieces, the biofilms abrade off the outside surfaces and their ability to retain effective biofilms is limited.

For both fixed and moving biomedias, the hydraulics of the liquid flow is very critical, in order to maintain treatment effectiveness.

Waving Biomedia stays in place, since it is weighted down, and it waves around in the water, instead of moving around. This gives the biomedia from accumulating suspended solids, like fixed biomedia, and its movement is independent of the hydraulics and mixing effectiveness, as is the case with moving biomedia. No screens are required to retain this biomedia, since the biomedia remains in place, and unlike fixed biomedia structure, it is simply placed within the lagoon or treatment system, since each biomedia piece is weighted down enough to keep it in one place. Schematic of the Waving Biomedia is shown on the next page. Each biomedia piece will be tied to the top to prevent it from falling when the reactor is decanted.

Waving Biomedia in water.

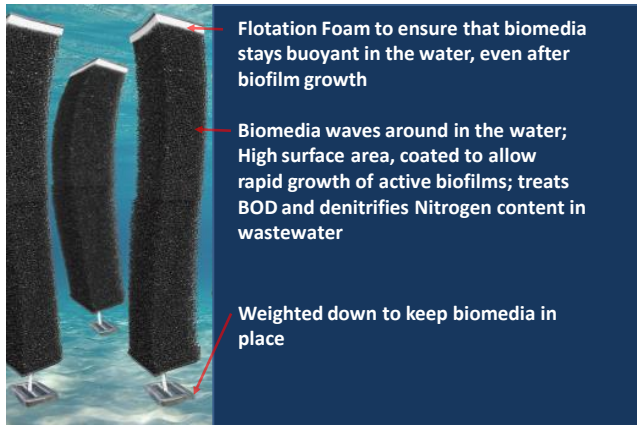

Nitrification/Denitrification

Waving biomedia is engineered to grow active biofilms, for treating organic contaminants and for nitrification and denitrification, as in the case of ammonia treatment. This biomedia, unlike other biomedias, is designed to create aerobic conditions on the outside area of the biomedia to nitrify the ammonia to nitrate/nitrite and anoxic conditions on the inside of the biomedia, in order

to denitrify the nitrate/nitrite to nitrogen gas. The biomedia has a chemical coating on the surface of the foam material which enables rapid attachment of the active biofilms. In typical uncoated biomedias, biofilm attachment and growth can take considerable time, while in our coated biomedias, full biofilm growth is usually achieved in a few hours. In addition, 10% of the media can be supplied with **biomass pellets** that contain organisms (aerobic bacteria, nitrifiers/ denitrifiers), to seed the bed during start-up. This allows faster start-up of the biobeds, especially since nitrifiers and denitrifiers are slow growing organisms. Furthermore, biofilm attachment of these slow growing organisms prevents washout, which is a common problem with suspended culture bioreactors. In addition, the attached biofilms increase active biomass concentrations in the bio-beds five to seven-fold over suspended culture bioreactors, thereby increasing biotreatment rates substantially.

Waving Biomedia Specifications

Dimensions: 4 inches x 4 inches x Depth of water

Surface Area: 280 ft²/ft³

Max. BOD Treatment Rate: 0.005 lb BOD/ft².day

Max. TKN Treatment Rate: 0.004 lb TKN/ft².day

Nominal distance between pieces: 2 feet

Arrangement: Distributed within the reactor vessel

Location: Near or soon after aeration, to maximize dissolved oxygen in the flowing water

Microbubble Aeration: An aeration system is among the most energy-intensive operations in wastewater treatment systems and is responsible for between 50-90% of total energy consumption in typical municipal installations. The optimum bubble size for aeration with compressed air and no mechanical mixing typically is considered to be 1 to 2 mm in diameter. This range of bubble diameter provides a compromise between the conditions for good mass transfer and efficient mixing. Gas transfer technologies that are able to produce

bubbles in the range of 10 to 1000 μm require a high power input, such as fine bubble aeration, jet aeration, etc. For standard submerged aerators, the bubble formation on the surface of aerator undergoes three stages: expansion stage, detachment stage, and coalescence due to bubble-bubble combination, which results in larger bubbles.

The transfer of oxygen from the air bubble to the water depends on wastewater characteristics: (1) concentration of soluble salts (Total Dissolved Solids or TDS), water temperature, water depth, total suspended solids (TSS), presence of surface active agents, etc.; (2) tank geometry, bubble size, kinetic energy of the fluid, etc.; and (3) extent and type of liquid mixing with the bubbles, which determines the path length of the air bubble.

The Actual Oxygen Transfer Rate (AOTR) = Standard Oxygen Transfer Rate (SOTR) $\times \alpha \times \beta \times \phi$ where SOTR is the oxygen transfer rate for pure water, α is the parameter that depends on the type of aeration device, intensity of mixing and tank geometry, β is the parameter that corrects for TDS, TSS, concentration of surface active agents, and ϕ is the parameter that adjusts for the oxygen solubility as a function of water temperature.

Table below lists the SOTR values for typical aerators, including the Absorption Aerator aeration system.

Type of Aeration System	SOTR Value (lbs oxygen/hp/hr)
Surface Aerator with draft tube	1.2 – 2.1
Surface high speed	1.2 – 2.0
Submerged turbine	1.0 – 2.0
Submerged turbine with sparger	1.2 – 1.8
Surface brush and blade	0.8 – 1.8
Fine bubble diffusers	0.5 – 1.5
Coarse bubble diffusers	0.3 – 0.8
Absorption Aerator	2.7 – 3.1

The Absorption Aerator's basic mechanism is to pump liquid water through a specially designed nozzle in which the high velocity of the liquid combined with swirl flow creates a negative pressure that draws in ambient air which is dispersed in the form of microbubbles (less than 50 μm in diameter). Figure 1 shows the basic schematic of the Absorption Aerator with its microbubble generation mechanism.

Basic mechanism of the Absorption Aerator.

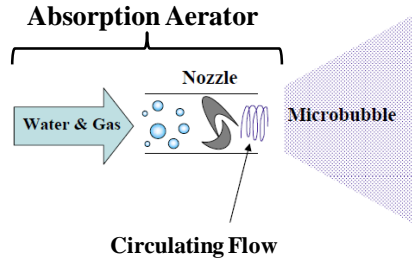

The Absorption Aerator has a high oxygen transfer efficiency due to the following factors: (1) high gas/liquid ratio = 2.2:1.0; (2) high intensity of mixing in the nozzle system; (3) no external blower required, which has major maintenance requirements; (4) the microbubbles have a large residence time within the water, thereby allowing the dissolved gases in the water, such as carbon dioxide, hydrogen sulfide, etc. to be effectively stripped out; and (5) 50 μm or smaller bubbles ultimately dissolve completely, creating an implosion that creates hydroxyl radicals; these radicals effectively treat the contaminants in the water, such as hydrolysis of fats and oils, oxidation of ammonia, which promotes biological activity.

Table 2 compares the ordinary bubbles, created by sparging, surface aeration, etc with microbubbles created by the Absorption Aerator.

Table 2. Comparison of the Absorption Aerator’s Microbubbles with Sparging Bubbles.

Bubble Size (μm)	Production Method	Properties
> 50	Submerged aeration, sparging, surface aeration, etc	Bubble coalesce into larger bubbles, rise quickly and break on the surface; oxygen transfer efficiency is less than 10% in clean water and less than 6% in wastewater
< 50	Absorption Aerator	Negatively charged surface of bubble prevents coalescence and bubble spends enough time within the water to achieve enhanced oxygen transfer; Once the bubble size becomes smaller than 10 μm due to air dissolution, the bubble does not rise to the surface, since its mass is balanced by its buoyancy; Microbubbles smaller than 10 μm effectively attach to submerged surfaces, thereby never rising to the water surface

Figure 2 shows a time lapse photograph of a glass tank, in which there is water intake going to the Absorption Aerator, outside the tank, and not shown in the pictures, and the outlet nozzle, within the tank

that discharges air/water mixture flow into the tank. The first picture shows the water intake and discharge nozzle, the second picture shows the onset of microbubbles leaving the discharge nozzle and the last photograph shows the tank filled with microbubbles of air.

Figure 2. Photographs showing the generation of microbubbles using the Absorption Aerator.

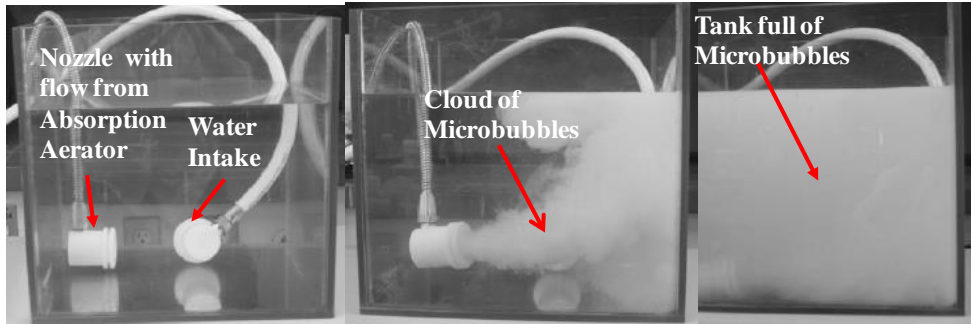

For a fixed volume of air, the surface area of the bubbles increases proportional to $1/\ell$, as the diameter of the bubble (ℓ) decreases, and this is shown in Figure 3.

Figure 3. Increase in surface area as a function of bubble diameter (ℓ) for a fixed air flowrate.

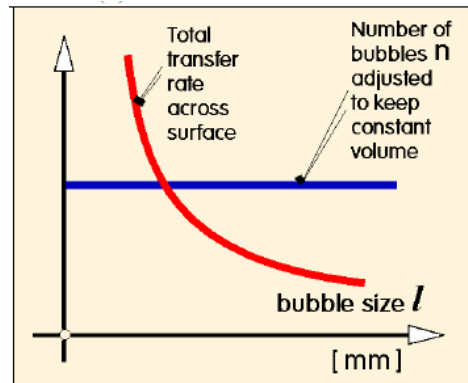

Clearly, as the bubble diameter decreases, the total transfer rate of oxygen across the bubble interface increases, due to increases in bubble area.

The bubble rise (residence time) for a water depth of 5 ft has been calculated as a function of bubble diameter, and this is shown in Figure 4.

Figure 4. Bubble Rise Time through water depth of 5 ft. as a function of Bubble Diameter.

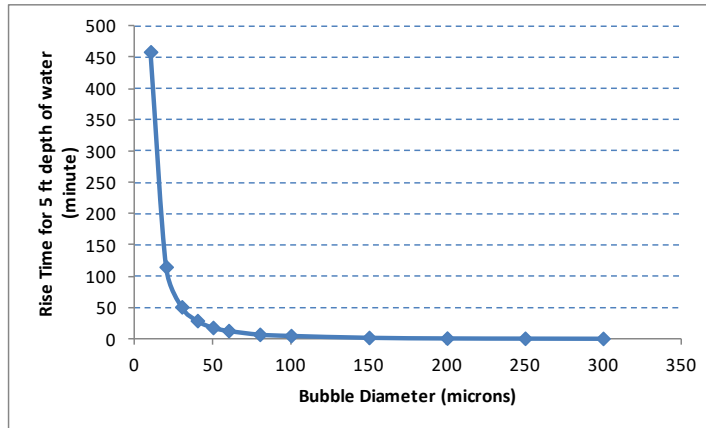

As the bubble size decreases below 50 microns (microbubbles), the rise time begins to increase rapidly for a tank with 5 ft depth of water. The above curve was constructed assuming that the water density is constant. However, as the bubble rise time increases, the density of the air-water mixture decreases, since at 70 deg F the density of air is 0.07 lb/ft³ while the density of water is 62.3 lbs/ft³. This decrease in air-water mixture density decreases the buoyancy of the bubble and slows down its rise rate through the water.

The mixing of the liquid in the bioreactor is very critical to maintain a nearly-uniform organic load throughout the reactor liquid. This is very essential to prevent uneven growth of biomass in the Waving Biomedia foam structure. This liquid mixing is achieved by recycling liquid back into the reactor during the aeration sequence.

This liquid mixing is achieved by using eductors to disperse the recycled liquid and air into the reactor liquid.

RETROFITTING PROPOSED TECHNOLOGIES

PHASE 1

The current SBR treatment process consists of two tanks, which are operated in the semi-batch mode. The following retrofits are proposed for one of these reactors in Phase 1 of the proposed project, with the second reactor being retrofitted in Phase 2.

1. Install 280 pieces of Waving Biomedia, with height equal to 15.0 ft, in one of the two SBR vessels. Each piece of Waving Biomedia has a cross-section of 4 inches x 4 inches, and height equal to 15.0 ft, which is the average depth of water in the reactor.

Calculations to determine the number of Waving Biomedia pieces per reactor are shown below:

Wastewater Flowrate	180,000 gpd	125 gpm	Two reactors
Influent BOD (mg/L)	250		
Effluent BOD (mg/L)	5		
Influent Ammonia-N (mg/L)	60		
Kinetic Parameters			
Yield Coefficient of VSS/BOD	0.5 lb VSS/lb BOD		
Decay Rate of Biomass	0.03 day ⁻¹		
Kinetic Rate for BOD	5 day ⁻¹		
Ks	60 mg BOD/L		
	40 mg/L COD		
Sludge Retention Time	10 days		
Observed Sludge Yield	0.38461538		
Increase in Biomass	141.459231 lbs/day		
Mass of BOD utilized	573.908135 lbs/day	per reactor	
Mass of Oxygen consumed per reactor	573.908135 lbs/day		23.91284 lbs/hr
Theoretical Air Requirement	32983.2261 ft ³ /day	22.90502 acfm	
Actual Air Requirement	164916.131 ft ³ /day	114.5251 acfm	Use 500 gpm aerator

The maximum biofilm thickness depends on the decay rate of biomass, which is in the range of 0.03 – 0.05/day, and depends on operating temperature. So the maximum amount of biomass in an aerobic bioreactor is given as follows:

$$\begin{aligned} \text{Maximum Amount of Biomass} &= \text{Growth Rate of Biomass (lbs/day)} / (\text{Biomass Decay Rate (day}^{-1}\text{)}) \\ \text{Growth Rate of Biomass in Bioreactor (lbs/day)} &= \\ &= \text{Wastewater Flowrate (MGD)} \times [\text{Influent BOD (ppm)} - \text{Effluent BOD (ppm)}] \times \text{Biomass Yield} \\ & \quad (\text{lbs biomass/lb of BOD}) \times 8.34 \text{ lbs/gal} \end{aligned}$$

where MGD is million gallons per day, ppm is parts per million and BOD is Biological Oxygen Demand.

If the maximum amount of biomass is uniformly distributed within all the biomedia, then the maximum steady-state biofilm thickness = Maximum volume occupied by biomass divided by the total protected surface area of the biomedia.

If there is sufficient biomedia present in the bioreactor, then the total protected surface area of the biomedia = Surface Area of protected surface per biomedia piece x number of biomedia pieces.

In order to have uniform distribution of biomass in all the biomedia present in the bioreactor, the concentration of BOD in the bioreactor has to be uniform, and this means that the bioreactor is completely mixed, as in an ideal stirred tank reactor.

The above calculations to determine the number of Waving Biomedia pieces needed in the bioreactor are shown below:

Biomass Growth Rate per reactor	286.954067	lbs/day			
Amount of Biomass in Reactor	9565.13558	lbs			
Volume of Biomass	153.042169	ft ³			
Max thickness of biofilm	0.00416667	ft	50% pore occupied by biofilm		
Surface area of biofilm needed	36730.1206	ft ²			
Height of Waving Biomedia	13	ft			
Surface Area of Each Waving Biomedia Piece	133.333333	ft ²			
Number of Waving Biomedia Pieces	275	per reactor	Use 280 pieces per reactor		
Volume occupied by Biomedia	2792.53333	gallons			
Volume of water in each reactor	124616.8	gallons			
% Reactor occupied by biomedia	2.24	%			

Liquid mixing is essential to achieve a uniform BOD concentration in the bioreactor, so that the biofilm thickness is within a narrow range. It improves movement of Waving Biomedia and transport of water through the open cell foam. It also increases rate of mass transfer and sloughing of biomass from the unprotected surfaces of the biomedia, while improving oxygen transfer and rates of denitrification.

2. Microbubble aeration system for aeration of the wastewater. This involves using a liquid pump, with a design flowrate of 500 gpm, 30 psi (14 HP). During the aeration step, wastewater from the SBR is pumped through the Absorption Aerator, which draws in ambient air and creates microbubbles in the wastewater. This provides dissolved oxygen in the wastewater, needed for effective biotreatment of the wastewater.

Calculations of air intake by the Absorption Aerator are given below:

26 psig Inlet Pressure

Q = 495 gpm

Open Discharge

Vacuum = 1.9" H₂O

Nozzle Diameter = 1.944"

Air Inlet (orifice) = (2) 2.0" Diameter Holes

1.9" H₂O = 1.9 x .5781 = 1.10 oz/in²

Velocity from plot @ 1.10 oz/in² = 95 fps. = 1140 in/sec.

Assume orifice C_D = 0.65

Area (2) 2.0" holes = 6.2832 in²

Effective Area = 6.28 x 0.65 = 4.08 in²

SCFM = $\frac{4.08 \times 1140 \times 60}{1728}$ = 161.5 (162 SCFM)

1728

$161.6 \text{ scfm} \times 60 \text{ min.} \times .0175^{**} = 169.58\# \text{ O}_2/\text{hr. available}$
 $169.58 \times 19.33\% \text{ efficiency}^* = 32.78\# \text{ O}_2 \text{ transferred/hr.}$

NOTE:

The above calculations were arrived at through the use of a pitot tube traverse across an air duct which communicates with a concentric jacket around the Absorption Aerator manifold.

The mixing of the wastewater in the reactor will be accomplished using eight (8) nozzles:

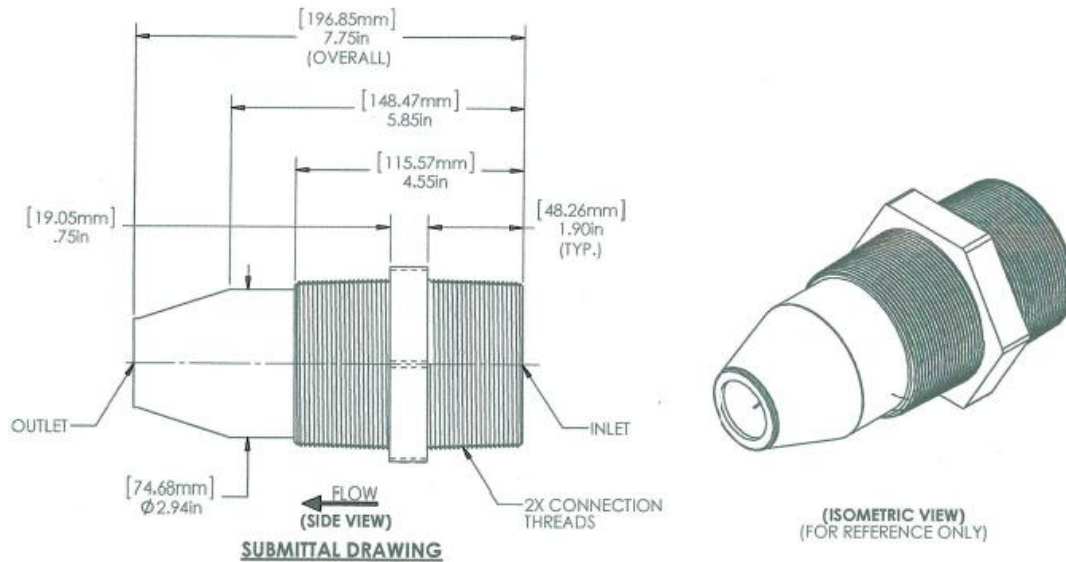

The eight nozzles will be pointing towards the four corners and four sides of the SBR tank, as shown in the drawings, presented later in this proposal. Each nozzle has openings of about 2 inches for the water to flow out at a high velocity, and this velocity is estimated to be 6.4 ft/sec.

The total motive flow is 500 gpm. The optimum inlet pressure to the Absorption Aerator is 26 psi. The pipes connecting the exit of the pump to the inlet of the Absorption Aerator will be 6 inches nominal diameter, Sch 80 PVC pipes. The pressure drop in this pipe and fittings, assuming a length of 40 ft, will be about 0.6 psi. The outlet pressure after the Absorption Aerator will be 4 psi, since the pressure drop across the aerator is 20 psi. Pressure drop in the nozzle for 62.5 gpm flowrate through each nozzle (500 gpm/8 nozzles) is calculated to be about 2 psi.

Schematic drawings (not-to-scale) of the proposed aeration system are shown below.

It is important to note that during the anoxic cycle duration, the recycle pump can be kept running and the ambient air inlet control valve will be closed to allow anoxic conditions to develop during this cycle step duration. The recycle pump will be shut off during the settling and decant stage.

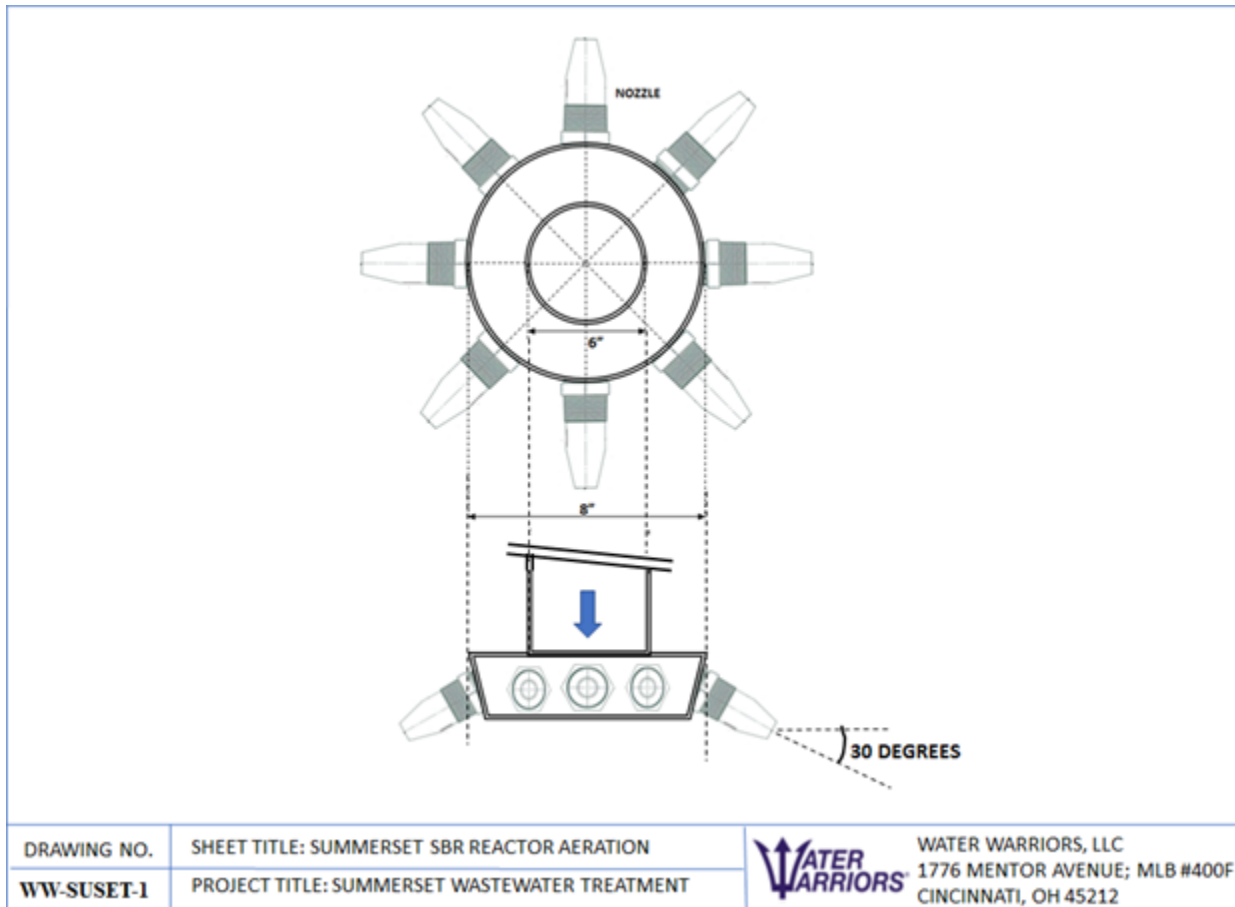

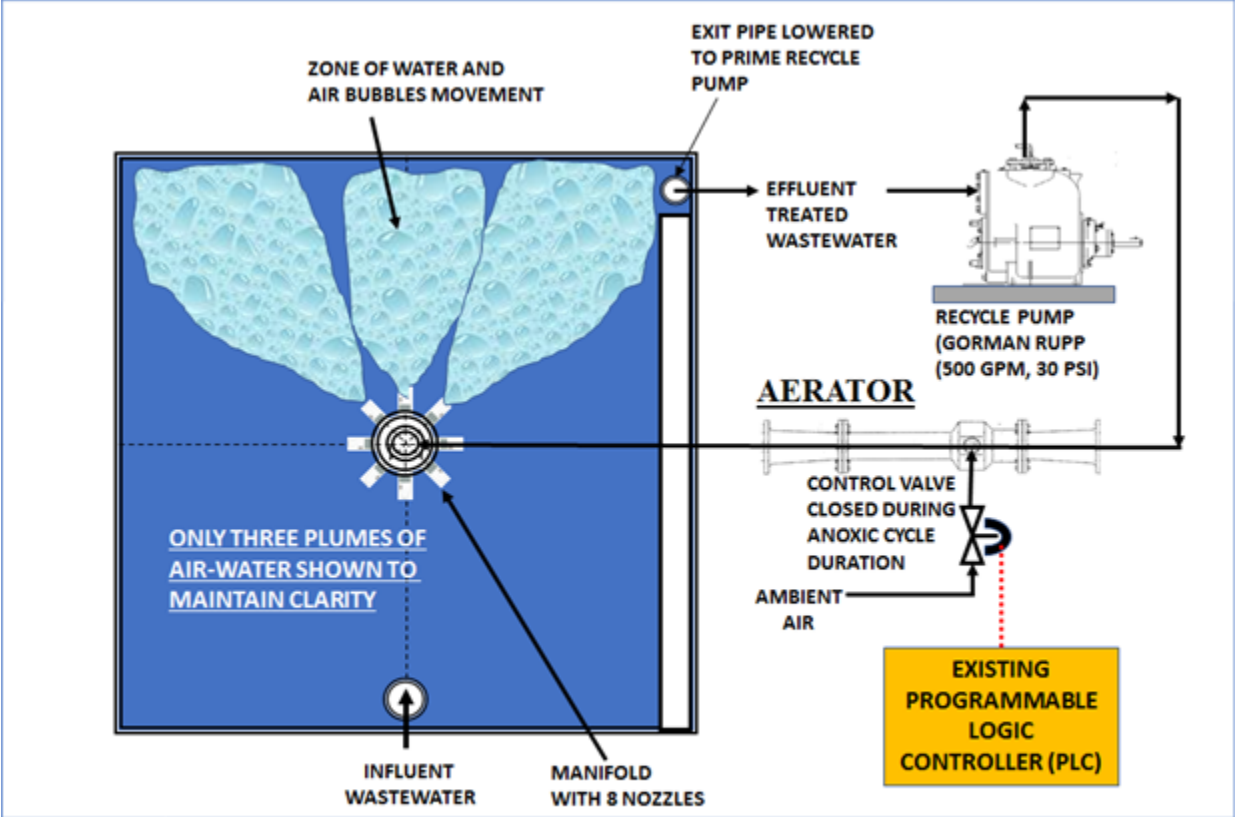

DRAWING NO.	SHEET TITLE: SUMMERSET SBR REACTOR AERATION	 WATER WARRIORS, LLC 1776 MENTOR AVENUE; MLB #400F CINCINNATI, OH 45212
WW-SUSET-2	PROJECT TITLE: SUMMERSET WASTEWATER TREATMENT	

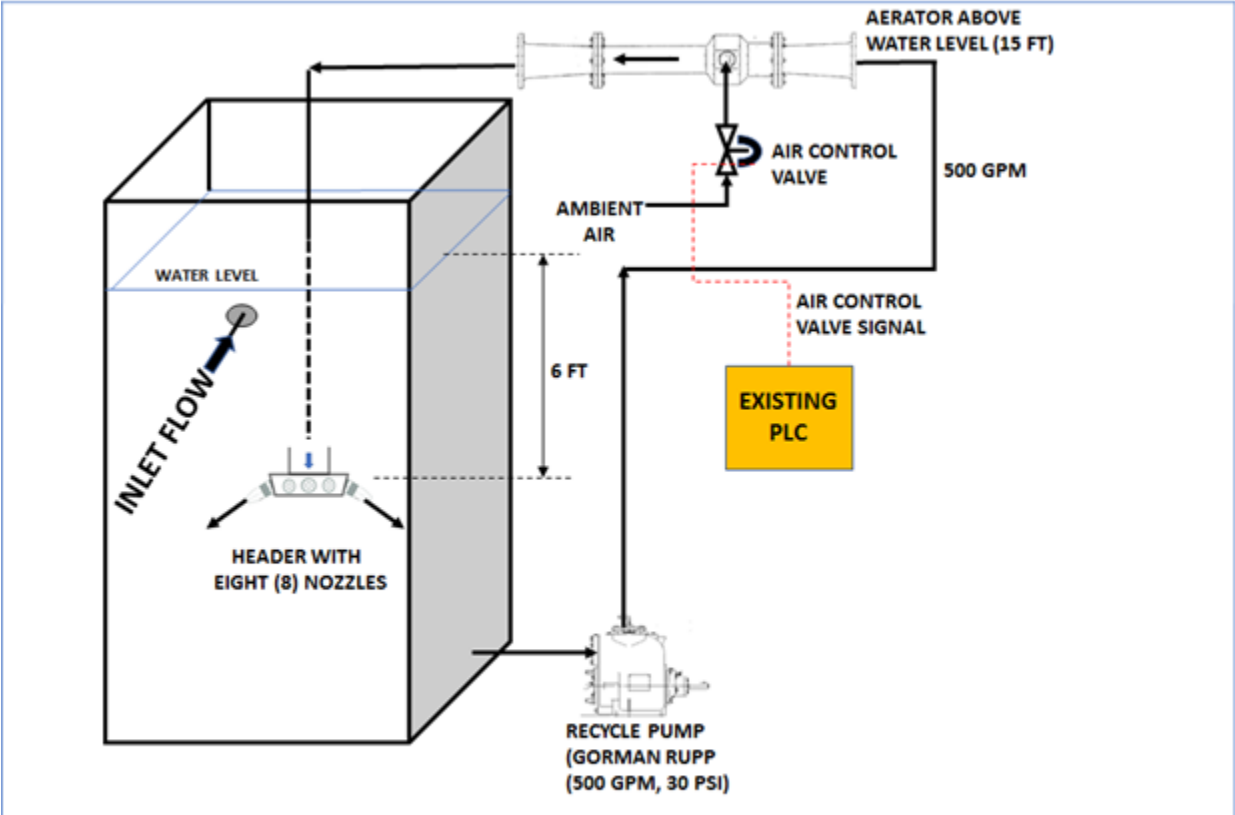

DRAWING NO.	SHEET TITLE: SUMMERSET SBR REACTOR AERATION
WW-SUSET-3	PROJECT TITLE: SUMMERSET WASTEWATER TREATMENT



WATER WARRIORS, LLC
 1776 MENTOR AVENUE; MLB #400F
 CINCINNATI, OH 45212

COST OF PROPOSED TECHNOLOGIES FOR PHASE 1

The total cost of the equipment for the proposed retrofit technologies will be **\$221,515** and the breakdown of this total cost is given below. These costs do not include shipping, packaging, permitting and on-site installation costs.

Two pumps (500 gpm, 30 psi, 14 HP each pump) (This does not include pump housing, VFD)	\$45,600
280 pieces of Waving Biomedia (15 ft height)	\$61,000
Cost of Absorption Aerator, 8 nozzles and manifold	\$28,100
Cost of Miscellaneous items and contingency	\$10,000
Direct Cost of Phase 1	\$144,700
Overhead costs (45%) of direct costs	\$76,815
Total Cost	\$221,515

This cost will include supplying 280 Waving Biomedia pieces (15.0 ft height) for one of the SBR vessels, two recycle pumps (14 HP each for one SBR vessel, and a second identical stand-by pump, which later can be used for the second reactor in Phase 2 or kept as a stand-by pump) for the microbubble aeration system, nozzles mounted on a header to disperse the air and water throughout the SBR vessels during the aeration step, Absorption Aerator for the aeration system.

The recycle pump, Absorption Aerator and PLC will be supplied as a single skid. The recycle pump will operate on 230V, 3 phase electrical power. The metering pump, tote mixer, PLC and sensors will operate using 110V, single phase. The skid will have a footprint of 4 ft x 6 ft.

The above quote does not include the cost of shipping, installation at the site and permitting costs, if any.

This project total will be paid as follows:

Initial payment with Purchase Order	40%
Second payment after all equipment has been received by Water Warriors	40%
Third payment after equipment has been received at site	10%
Payment after commissioning of retrofit modifications	10%

The proposed retrofit system has major advantages over other possible solutions:

1. The aeration process is a simple process with minimal moving parts (recycle pump only), which can effectively treat the wastewater;
2. The proposed design aerates and moves the water simultaneously, and this water movement will increase the mixing level within each of the SBR vessels;
3. Simple installation, since the aeration nozzles and piping are installed below the water surface. The pump and Absorption Aerator are outside the reactors, and will be supplied on a skid, with a control box, which can be installed next to the SBR vessels;
4. High efficiency of oxygen transfer to the lagoon water and enhanced mixing of the water; Absorption Aerator's oxygen transfer efficiency is 2-3 times higher than bubble aeration;
5. Low energy consumption, since the Absorption Aerator delivers dissolved oxygen to the water at about ½ the horsepower consumed using bubble aeration; Currently, the aeration system uses 25 HP blowers, while the proposed aeration system will use 9 HP, which will save 64% of the current electrical power costs;
6. Because the Absorption Aerator effectively strips off carbon dioxide generated by aerobic microorganisms, it will raise the pH non-chemically thus contributing to reduced chemical usage. This becomes very evident when reviewing the following formula:

$$\text{pH} = 6.35 + \log(\text{alkalinity}/\text{carbon dioxide})$$

By raising the pH, non-chemical nitrification can begin almost instantly with the increase in pH above 6.8 levels; Obviously, the greater the increase in pH, the more rapidly nitrification occurs thus making nitrogen bioavailable for Colony Forming Units (CFUs);

7. The motive liquids continuously supply highly oxygenated liquids directly into the media keeping the biomass viable and removing carbon dioxide from the off-gassing of the microorganisms;
8. Less sludge production, since most of the biomass will be retained on the Waving Biomedia, which increases Sludge Retention Time (SRT) and hence reduces net sludge production;

9. Cost-effective, since the cost of the equipment will have a low payback time, when compared to the costs involved in using diffuse aerators.

In addition to saving some operating costs, there are other significant benefits that have not been monetized. These benefits are as follows:

1. Improved performance in terms of reducing 5-day BOD and TKN in the effluent and meeting the required pollutant discharge limits;
2. Reduction in sludge production, which has to be dewatered and disposed; and
3. Reduce the yearly electrical operating cost of the aeration system, while improving effluent water quality and increasing plant treatment capacity.

ABOUT WATER WARRIORS

WATER WARRIORS, Inc. (WATER WARRIORS) has the experience needed for designing advanced water treatment systems.. Our broad spectrum of applications includes chemical, petrochemical, industrial, mineral, wood products, carbon products, pharmaceutical, automotive, and many other applications.

WATER WARRIORS founders have executed several projects worldwide and is headquartered in Cincinnati, Ohio. We offer our worldwide customers the following benefits:

- Strong process design with 20+ years experience
- Custom design to suit project requirements
- Complete system integration experience
- Strong project management & engineering team
- Strong after market service team
- Respected industry reputation
- Guaranteed system performance

Invoice Date: 06/02/2020

INVOICE

#0602



Client:
City of Summerset
Lonnie Harmon
7055 Leisure Lane
Summerset, SD 57718

Item	Quantity	UM	Part Number	Line Description	Price \$	Extension \$
001	1	EA	WW280WBMA	Retrofit and Upgrading SBR	\$221,515	\$221,515

40% Initial Payment w/ Purchase Order

TOTAL

\$88,606

Contact Information:

Water Warriors Inc., 1776 Mentor Ave 400F

Cincinnati, Ohio 45212

Steve Chamberland schamberland@waterwarriorssolutions.com

May 2020

<u>Name</u>	<u>Address</u>	<u>Account#</u>		<u>Amount</u>	
Amanda Ulmer		ULMAM	\$	68.68	ACH Return
Summerset Hotel	7900 Stage Stop Rd	HOTEL	\$	97.70	New Ownership. Adj Acct to Bill
Summerset Hotel	7900 Stage Stop Rd	HOTEL	\$	54.12	Mortin Adjustment
Stagebarn Lodging	7900 Stage Stop Rd	STGBA	\$	127.84	New Ownership. Adj Acct to Bill
Doris Black	10851 Freedom Pl	BLACH	\$	5.00	Late Fee Removal
Michon Holt	6526 Leisure Lane	HOLMI	\$	73.68	PMT applied to wrong acct
Nicholas Holzer		HOLNI	\$	68.68	PMT applied to wrong acct
			Total: \$	495.70	